

# Stellfuß D113

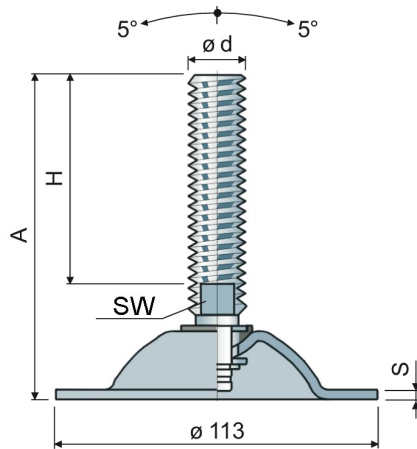
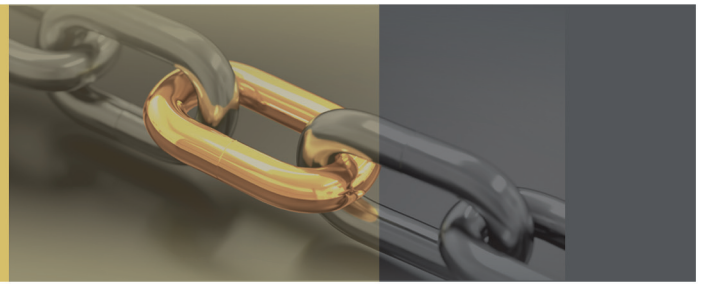

Teller aus Stahl  
Standardverpackung: 8 Stück  
Weitere Abmessungen auf Anfrage

Art.-Nr. Spindel verzinkt	Art.-Nr. Spindel Edelstahl	$\varnothing d$	A mm	H mm	SW mm	Max. statische Belastung daN
98 / 7584	98 / 7585	M16	100	58	13	1500 (verzinkt) S = 3,5  1000 (Edelstahl AISI 304) S = 3
98 / 7918	98 / 7919	M16	161	119	13	
98 / 7586	98 / 7587	M16	187	145	13	
98 / 7588	98 / 7589	M16	243	201	13	
98 / 82140	98 / 82141	M18	199	157	15	
98 / 7590	98 / 7591	M20	152	107	17	
98 / 7592	98 / 7593	M20	180	135	17	
98 / 7594	98 / 7595	M20	202	157	17	
98 / 7596	98 / 7597	M24	138	90	19	
98 / 7598	98 / 7599	M24	175	127	19	
98 / 7600	98 / 7601	M24	210	162	19	
98 / 7602	98 / 7603	M30	173	125	24	
98 / 7604	98 / 7605	M30	233	185	24	

## Zubehör

### Muttern UNI 5588-65; Verpackungsgröße: 24 Stück

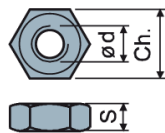

Artnr. verzinkt	Artnr. Edelstahl	$\varnothing d$ mm	S mm	Ch. mm
7275	7277	M16	13	24
7276	7278	M20	16	30
7279	7280	M24	19	36
7281	7282	M30	24	46

### Scheiben UNI 6592-69; Verpackungsgröße: 24 Stück

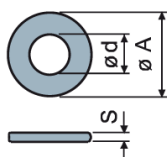

Artnr. verzinkt	Artnr. Edelstahl	$\varnothing d$ mm	S mm	A mm
7289	7291	17	3	30
7290	7292	21	3	37
7293	7294	25	4	44
7295	7296	31	4	56