

# Stellfuß D102

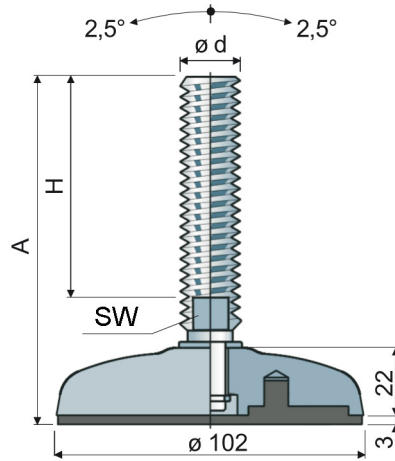
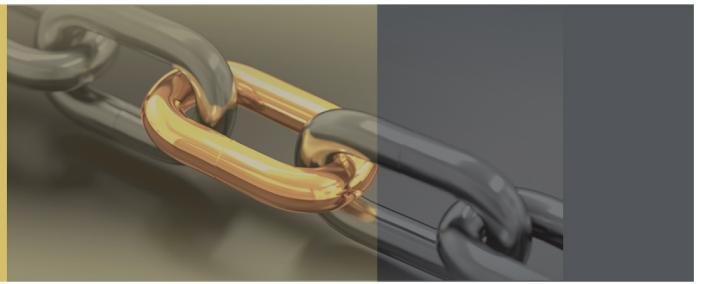

Teller aus vernickeltem Stahl  
 Standardverpackung: 8 Stück  
 Dämpfungsplatte PVC  
 Weitere Abmessungen auf Anfrage

Art.-Nr. Spindel verzinkt	Art.-Nr. Spindel Edelstahl	$\varnothing d$	A mm	H mm	SW mm	Max. statische Belastung daN
97 / 7550	97 / 7551	M16	101	58	13	5000
97 / 7912	97 / 7913	M16	162	119	13	5000
97 / 7182	97 / 7183	M16	188	145	13	5000
97 / 7184	97 / 7185	M16	244	201	13	5000
97 / 82146	97 / 82147	M18	200	157	15	5000
97 / 7186	97 / 7187	M20	153	107	17	5100
97 / 7552	97 / 7553	M20	181	135	17	5100
97 / 7188	97 / 7189	M20	203	157	17	5100
97 / 7190	97 / 7191	M24	139	90	19	5200
97 / 7554	97 / 7555	M24	176	127	19	5200
97 / 7192	97 / 7193	M24	211	162	19	5200

## Zubehör

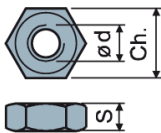

### Muttern UNI 5588-65; Verpackungsgröße: 24 Stück

Artnr. verzinkt	Artnr. Edelstahl	$\varnothing d$ mm	S mm	Ch. mm
7275	7277	M16	13	24
7276	7278	M20	16	30
7279	7280	M24	19	36

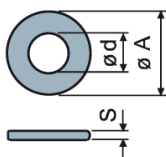

### Scheiben UNI 6592-69; Verpackungsgröße: 24 Stück

Artnr. verzinkt	Artnr. Edelstahl	$\varnothing d$ mm	S mm	A mm
7289	7291	17	3	30
7290	7292	21	3	37
7293	7294	25	4	44